

ACH

CORPORATE
HELICOPTERS

ACH125



AIRBUS



ACH 125

Voe a lenda

Desenvolvido com foco em desempenho, criado para voos confortáveis e tranquilos, o ACH125 é um membro da família Esquilo - o helicóptero a turbina favorito do mundo.

Mais Alto
Mais Longe
Melhor



O ACH125 supera todos os outros helicópteros monoturbinas em desempenho, versatilidade e segurança, destacando-se em ambientes quentes, altos e extremos.



Poucos estiveram aqui.
Somente um pousou.

O ACH125 quebrou o recorde de pouso e decolagem de maior altitude realizado no Monte Everest - Himalaia a 8.848 metros (29.029 pés) - um título atual.





Faça suas maiores
ambições voarem.





Voe para longe da costa, para picos ou ilhas distantes. Comece o fim de semana em grande estilo.





Se livre do trânsito.

Uma reunião de emergência, horários apertados.

O ACH125 tem a potência e a velocidade para chegar lá com tempo de sobra.





Aproveite a experiência.

A certeza de ter escolhido o melhor. Tecnologia comprovada, estilo autêntico, desempenho e confiabilidade.



Esportivo
e estiloso



Estilo personalizado pela ACH

Um ambiente leve e dinâmico criado a partir de uma cabine com design atraente. Do couro estampado, tratamento liso e acabamento, tudo recebe atenção especial.



Estofados feitos do melhor couro, recortados com precisão e costurados à mão com cuidado por artesãos experientes.

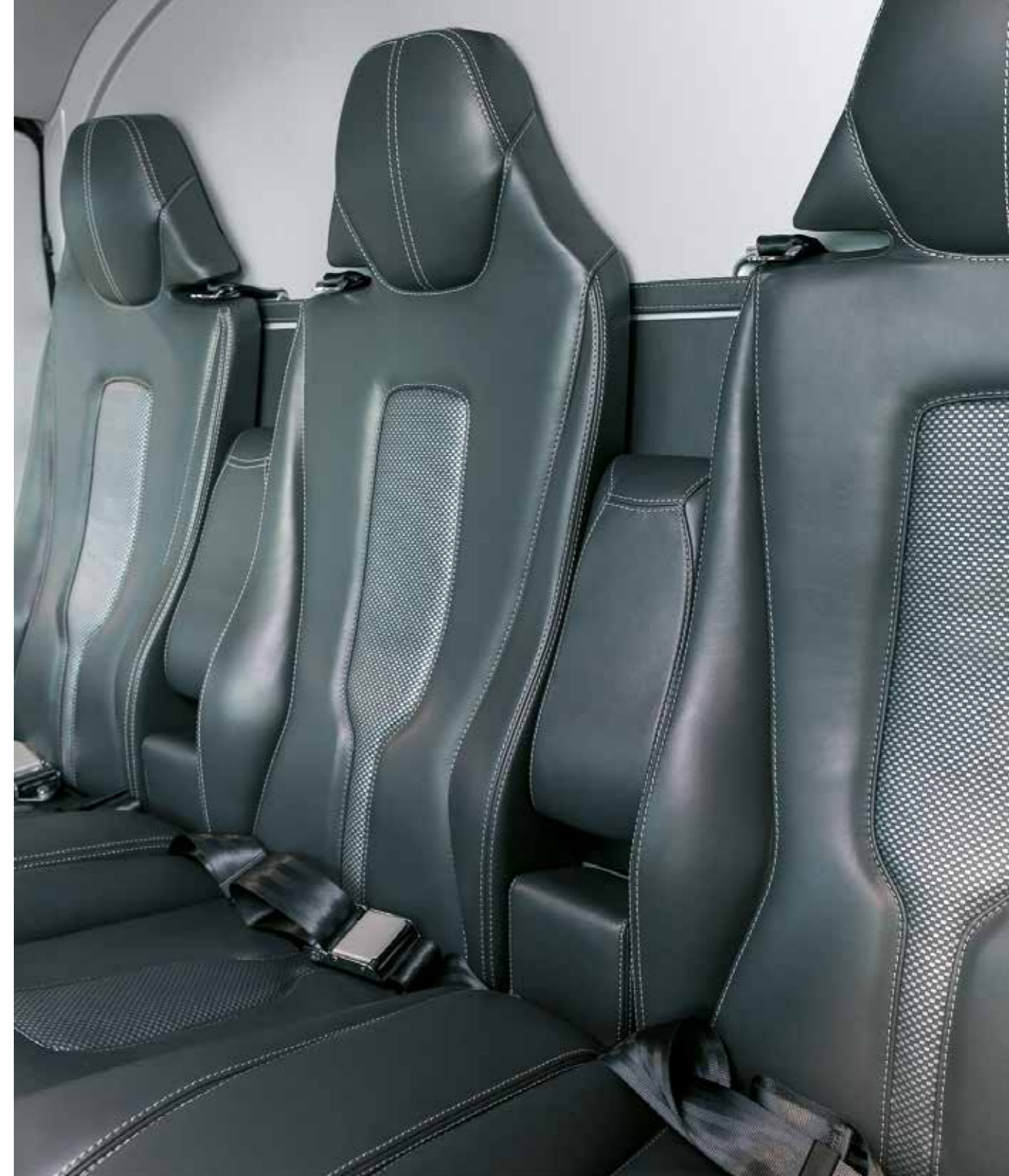

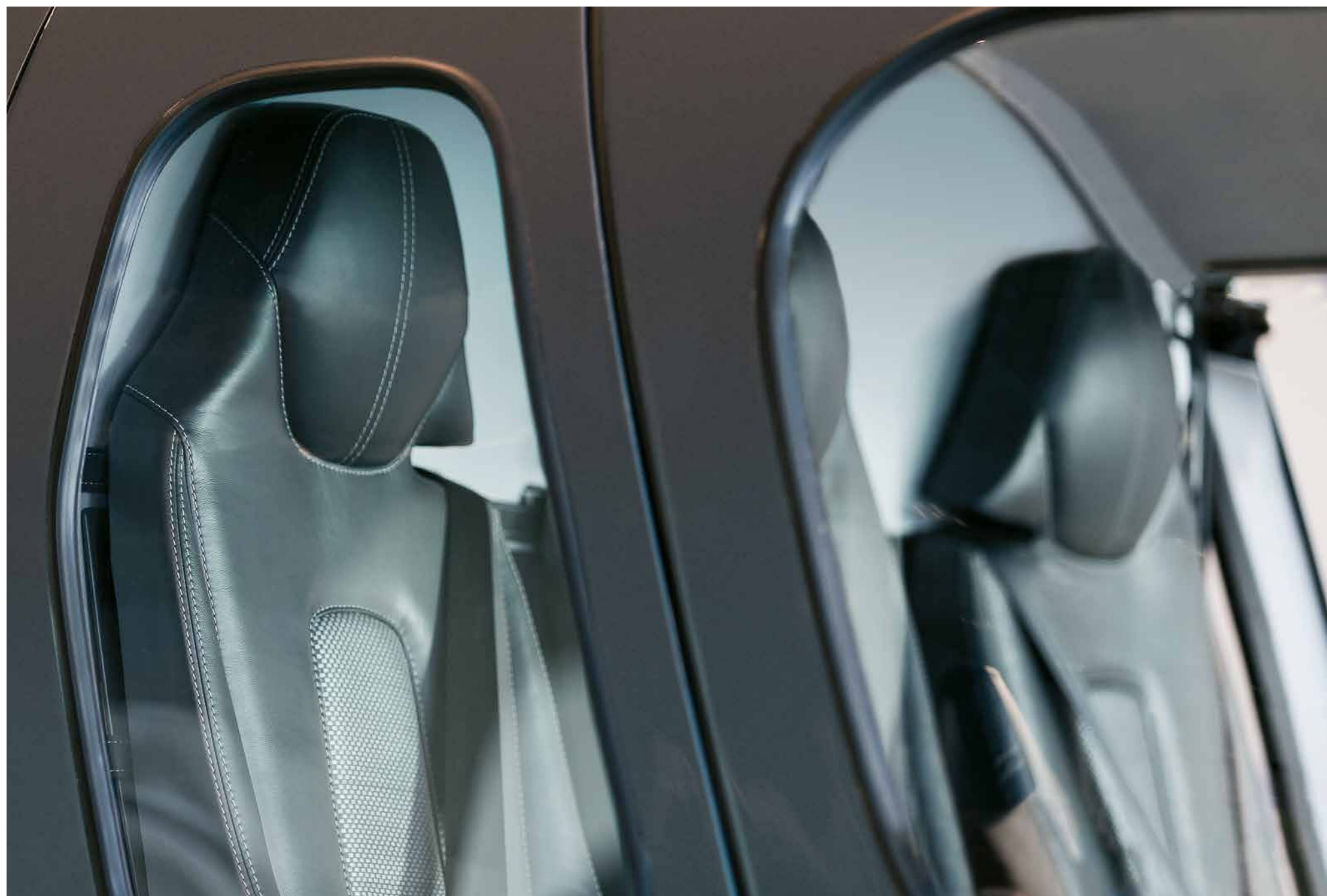

Compartilhe uma
viagem luxuosa.
Cinco assentos
confortáveis
posicionados para
a frente da
aeronave.



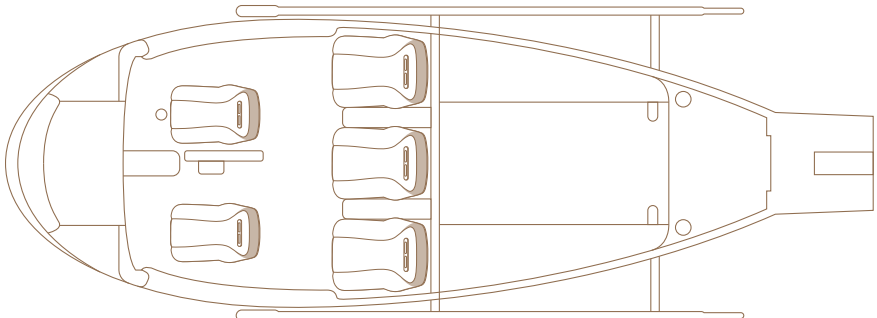
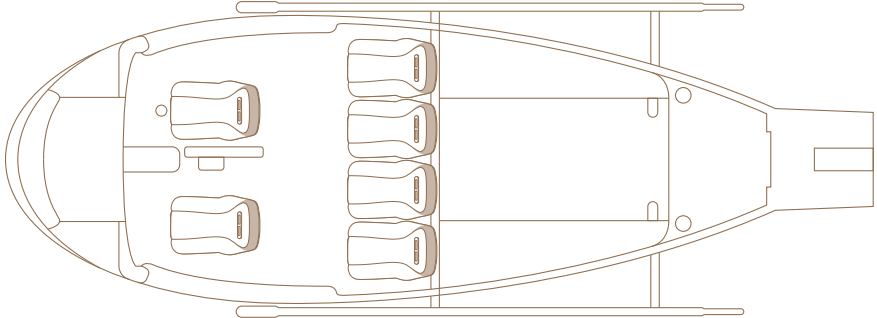



Desempenho e espaço surpreendentes proporcionam aos passageiros um passeio emocionante.



O seu helicóptero com um visual exclusivo. Exprese sua própria individualidade com interior e exterior personalizados.

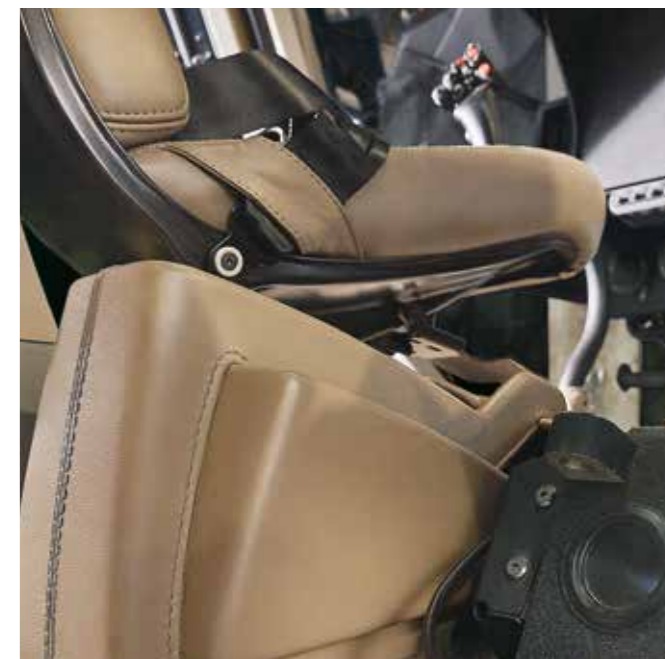

Feito para
você



Crie sua própria
versão

A experiência ACH125 traz
o seu projeto para a
realidade.



Tornando o melhor ainda melhor

Comece onde os outros param.

Confiabilidade comprovada, suporte personalizado e desempenho de sobra - tudo em um só helicóptero.

O ACH125 reduz da carga de trabalho do piloto com aviônicos aprimorados.

A lenda atingiu mais de 30 milhões de horas de voo.

A história de sucesso continua.







Até 5
passageiros

Duração máxima de voo:

4 h 57 min

Velocidade máxima de cruzeiro:

264 km/h





Aproveite todos os benefícios da aeronave mais voada no mundo, desde a versatilidade, até a liquidez.

Importante
para você,
essencial
para nós



Todos os helicópteros ACH são únicos.
Assim como todos os nossos clientes.
Distinto e com padrões elevados.

Sentimos uma grande responsabilidade para com os nossos clientes.
Afinal, a busca pela perfeição do helicóptero também inclui a busca pelo serviço perfeito.

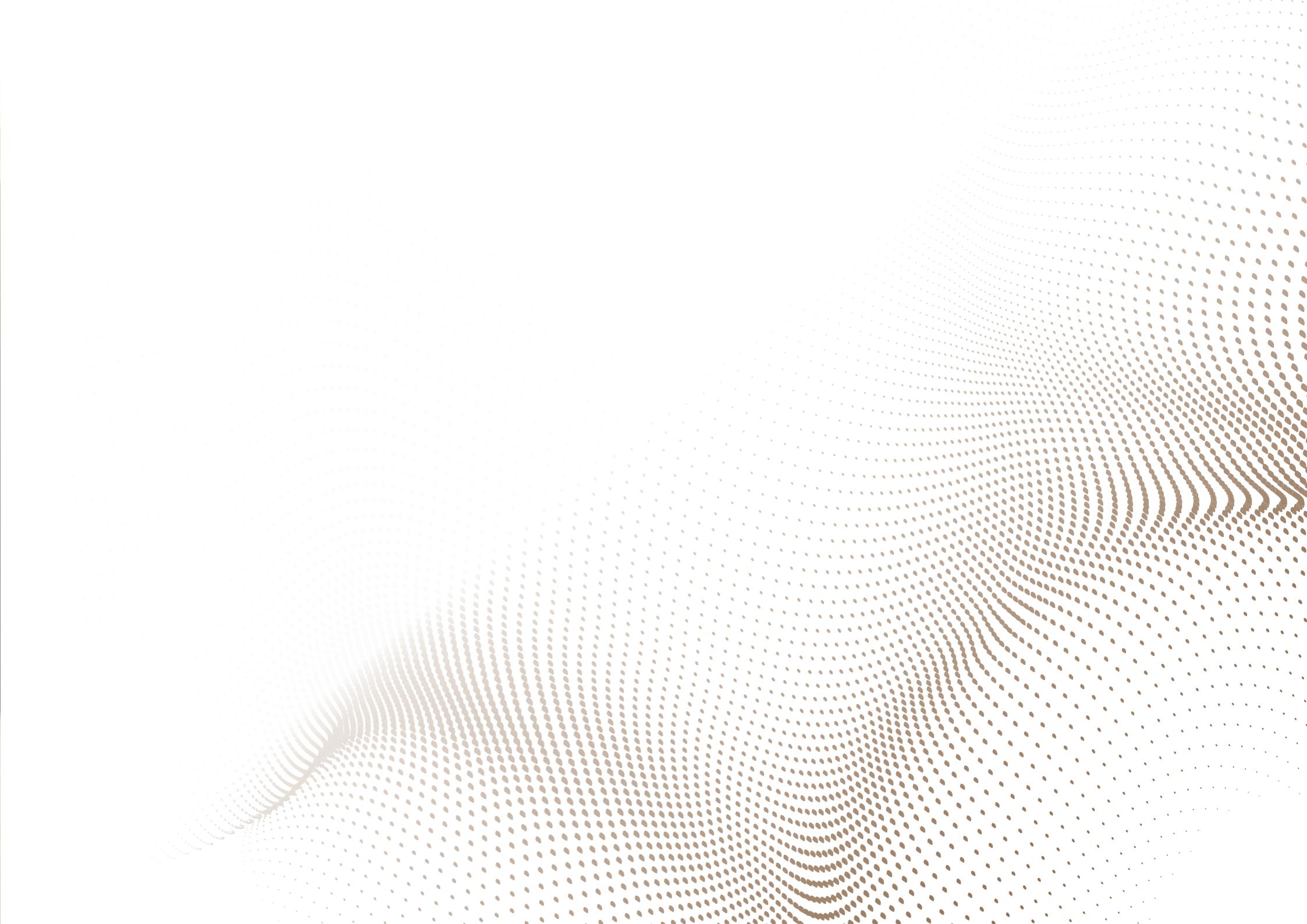

AIRBUS

©AIRBUS HELICOPTERS
Aéroport International Marseille Provence
13725 Marignane Cedex - France

All rights reserved. Airbus logo and Airbus Helicopters products and services names are registered trademarks.

Concept Design by Airbus Multi Media Support 20180527.
Photos by Airbus, Airbus Helicopters, Lorette Fabre, Camille Moirenc, Antonny Pecchi, Patrick Penna, Rupert Piece, Eric Raz, Thierry Rostang, Zsuzsanna P. Wagenhoffer, Shutterstock.

Printed in France by Art & Caractère. July 2018.

Confidential and proprietary document. This document and all information contained herein is the sole property of AIRBUS S.A.S. No intellectual property rights are granted by the delivery of this document or the disclosure of its content. This document shall not be reproduced or disclosed to a third party without the express written consent of AIRBUS S.A.S.

This document and its content shall not be used for any purpose other than that for which it is supplied. The statements made herein do not constitute an offer. They are based on the mentioned assumptions and are expressed in good faith. Where the supporting grounds for these statements are not shown, AIRBUS S.A.S. will be pleased to explain the basis thereof.

This brochure is printed on Stucco Old Mill, Symbol Tatami and OP Polar.

This paper is produced in factories that are accredited EMAS and certified ISO 9001-14001, PEFC and FSC CoC. It is produced using pulp that has been whitened without either chlorine or acid. The paper is entirely recyclable and is produced from trees grown in sustainable forest resources.

The printing inks use organic pigments or minerals. There is no use of basic dyes or dangerous metals from the cadmium, lead, mercury or hexavalent chromium group.

The printer, Art & Caractère (France 81500), is engaged in a waste management and recycling programme for all resulting by-products.



